

Construction Specifications

Prima Bianco Door:

The Prima Bianco full overlay door and corresponding drawer front are made up of a ¾" MDF square slab. The doors are finished with a white, high gloss acrylic polymer composite and matching edge banding.

Hinges:

The Prima Collection features fully concealed 6-way adjustable clip-on hinges. Prima doors and drawers come standard with a soft-close mechanism. Hinges open at 110° on all Prima product lines.

Please note: Specialty cabinets such as lazy susans etc., do not feature the soft-close mechanism.

Drawers:

The Prima line's meta-box drawers have a ⅝" combi-plywood underside, and run on full extension soft-close slides.

Shelving:

Prima shelves are ¾" combi-plywood, fully adjustable, and supported by a bronze plated shelf clip. Prima base cabinetry shelves are 18" deep and also fully adjustable.

Side & Back Panels, Tops and Bottoms:

The Prima series features a frameless construction, assembled with wooden dowels and glue. Side panels and undersides are made of ¾" combi-plywood, and rear panel is made of ¼" MDF.

All four sides are supported by combi-plywood rails. All base cabinets in the Prima line come with full ¾" combi-plywood dust covers.

Wall Cabinets:

Because of its frameless construction, the depth of our Prima wall cabinets are slightly deeper at 13" with an inside clearance of 12".

Toe Kick:

Added to each assembled cabinet in the Prima collection is a ¾" x 4½" combi-plywood toe kick. Also offered are additional 8' lengths of ¼" thick toe kicks to eliminate the appearance of joints between cabinets. Our 8' lengths are available in matching colors to our cabinetry as well as stainless steel.

Construction Specifications

- 1 ¾" high-gloss white acrylic door & drawer front
- 2 Clip-on six way adjustable self close hinges
- 3 Meta-box soft close drawer box with ⅝" combi-plywood bottom
- 4 2⅞" interior drawer height
- 5 ¾" combi-plywood frameless construction
- 6 ¼" 5-piece MDF backing
- 7 ¾" combi-plywood side panels
- 8 ¾" combi-plywood adjustable shelving
- 9 ¾" x 4½" combi-plywood toe kick
- 10 Full dust cover
- 11 Base cabinet has 18" deep shelves
- 12 Wall Cabinet are 13" deep with 12" interior depth

COMBI-PLYWOOD

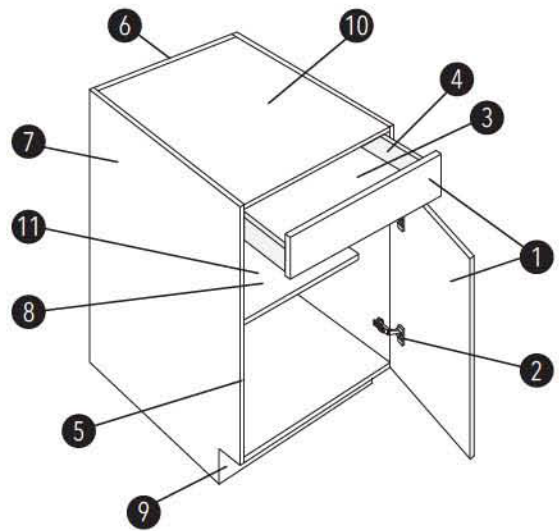
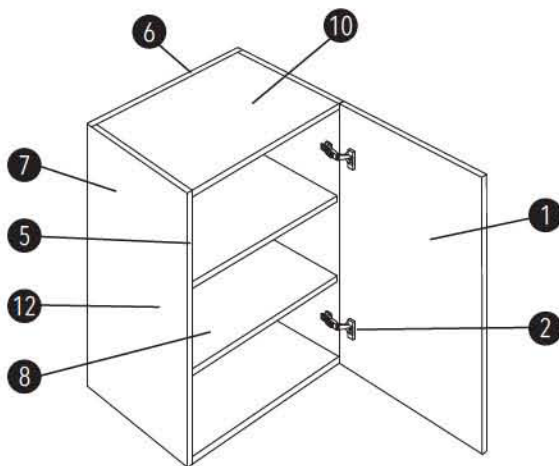
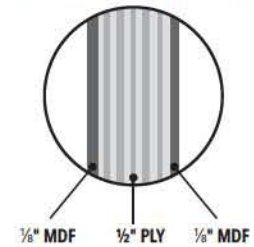

Door Style

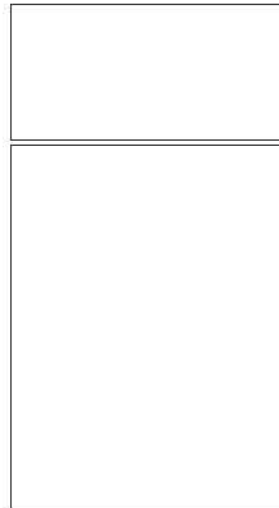

BIANCO

COLOR

High-gloss white acrylic polymer

- *3/4" MDF slab door and drawer front*
- *Covered with high gloss white acrylic polymer and matching edge-banding*
- *White melamine interior*

Order Information

Orders are accepted from accounts that are in good standing. We recommend placing your orders online for faster processing and delivery.

Orders may be submitted 24 hours a day via one of the following methods:

- 1) Online: Go to: <https://ezpricing.fabuwood.com/> to access Fabuwood's EZ Pricing Program. Orders exported from 20/20 & ProKitchen in an .xml file format can be uploaded directly into the EZ Pricing Program.
- 2) Email: orders@fabuwood.com
- 3) Fax: 201-432-6055

Forms are processed in the order they were received. Fabuwood has a strict policy not to accept verbal orders at any time. Fabuwood customer service representatives will need your account number each time you contact us. Please have your information on hand.

ORDER PLACEMENT:

- To place an order with Fabuwood, please use our interactive forms, found in the Dealer's Corner on our website. 20/20 & ProKitchen order forms are also accepted provided that Fabuwood nomenclature is used.
- Orders should be submitted with a cover page. Cover pages must include:
 - 1) Name of dealership
 - 2) Name of client/designer
 - 3) Purchase order number
 - 4) Total amount of pages in order
- According to your requested shipping timeframes, Fabuwood schedules orders based on when they were submitted. Should you have more than one order, it is best to batch them together and submit them to Fabuwood simultaneously.
- Please make sure to specify your shipment method at the time of purchase.
- Should your order need to be shipped to a location that differs from your usual delivery address, it must be noted at time of purchase along with a contact name and phone number for the location. Additional charges will apply.
- On average, orders are ready to leave Fabuwood's warehouse within 7 business days from confirmed and signed orders. For rush orders, please contact your customer service representative to discuss express fulfillment options. Rush orders will incur additional fees.
- For orders containing modifications or custom finishing, please expect additional business days for completion.
- Prices listed in latest spec book reflect Fabuwood's list price. Please contact your customer service representative for multiplier and freight pricing.

ORDER PROCESSING:

- Upon receipt of your order, your assigned customer service representative will enter your request as a quote and will subsequently send it back for your approval.
- Please take the time to thoroughly proofread all Fabuwood quotes.

Make sure all information, including quantity, color, style, shipment method, and pricing are correct. Once quotes have been signed and resubmitted, Fabuwood is not responsible for typos or mistakes made.

- Should the order require any corrections or revisions, email them to orders@fabuwood.com or fax to: 201.432.6055. Quotes are valid for 30 days only.
- Once revisions have been submitted, Fabuwood will send you a revised quote for a final approval. When we receive your signature we can begin processing your order.
- By signing the quote, the dealer takes full responsibility for any and all errors on order forms.
- Once quotes are signed and returned you will receive an order confirmation email which will include your order's ESD. ESD's are determined by the date the order will ship out or be available for pickup. For orders entered online, you can select an ESD based on your schedule. However, once an ESD is selected, the order will not be ready prior to the selected date.
- Order pickups must be scheduled one business day in advance by no later than 3pm EST. To schedule a pickup, please contact the pickup department at 201-432-6555 ext #372.
- Orders not picked up after 4 weeks will be stored at the dealer's expense. No additional orders will be released until storage fees have been paid, or order is picked up. Storage fees will accrue on a monthly basis at the rate of \$50 per palette.
- If you would like your order to be ready later than the regular ESD, please make a note on your order to avoid storage fees.

ORDER REVISION PROCEDURES:

- Once a quote has been approved, any revisions or cancellations will result in restocking fees. Also, modified/custom items cannot be revised or canceled once approved.
- Verbal cancellations or revisions are not accepted at any time.
- Merchandise that has left Fabuwood's facilities cannot be returned or exchanged.

SHIPPING SHORTAGES & DAMAGES:

Order shortages such as missing items and/or any visible shipping damages must be noted on the shipping receipt and signed by both the driver and the recipient. It is then the customer's responsibility to notify Fabuwood of any such issues within 24 hours of accepting the delivery. Any orders accepted and signed by the customer without any such note, will be considered complete. All other shipping damages must be claimed by the customer within 5 days. All items that have been installed and/or are not in their original packaging cannot be claimed as damaged.

5 Year Limited Warranty

COVERAGE OF WARRANTY

Fabuwood Cabinetry Corp ("Fabuwood") is pleased to provide the following limited warranty on all cabinets imported to and assembled and sold in the United States by Fabuwood. This warranty does not cover cabinets sold or shipped outside of the United States. This limited warranty is subject to all limitations, exclusions, disclaimers and procedures set forth herein. Fabuwood warrants to the original purchasing consumer that all cabinets purchased from Fabuwood will be free from all unnatural defects in material and workmanship in accordance with the Fabuwood quality standards sheet under normal residential use for 5 years from the date of the original purchase or as long as the original purchasing consumer owns the home in which such cabinets are installed, whichever is less. This warranty is non transferable to subsequent owners of the home.

EXCLUSIONS

THIS WARRANTY SUPERSEDES ANY AND ALL PREVIOUS WARRANTIES BY FABUWOOD AND CONSTITUTES THE EXCLUSIVE REMEDY AGAINST FABUWOOD FOR ALL DEFECTS, DAMAGES AND WORKMANSHIP. THERE ARE NO IMPLIED WARRANTIES EXTENDING BEYOND THE TERMS OF THIS WARRANTY. FABUWOOD SHALL NOT BE LIABLE FOR ANY INDIRECT, SPECIAL, PUNITIVE, INCIDENTAL OR CONSEQUENTIAL COSTS, EXPENSES OR DAMAGES. THIS WARRANTY GIVES YOU SPECIFIC LEGAL RIGHTS, AND YOU MAY ALSO HAVE OTHER RIGHTS, WHICH VARY FROM STATE TO STATE. IT IS POSSIBLE THAT ONE OR MORE OF THE LIMITATIONS AND EXCLUSIONS IN THIS WARRANTY MAY NOT APPLY TO YOU. THIS WARRANTY APPLIES ONLY TO FABUWOOD PRODUCTS PURCHASED ON OR AFTER MARCH 15, 2014

LIMITATIONS

This warranty shall become void if the cabinets, cabinetwork, drawer slides or hinges are modified from its original form, improperly installed or damaged prior to or during the installation, or used in any way other than for residential purposes. This warranty covers only parts and materials of the cabinets as supplied by Fabuwood. This warranty does not cover any products used or installed in connection with cabinets, such as gas or electric appliances, countertops, or plumbing fixtures. This warranty does not apply to products installed in locations that do not maintain year-round environmental controls. This warranty shall not apply to damages caused by transportation, storage, dirt, chemicals, exposure to moisture, humidity or excessive heat or cold, nor does it cover defects arising from normal wear and tear, misuse, neglect, accidents, alterations, improper use or failure to maintain properly, house settling, or acts of God. No installer, retailer, distributor, agent or employee of Fabuwood has the authority to alter the obligations or limitations in this warranty.

QUALITY STANDARDS

This warranty covers all damages and unnatural defects that are deemed as such under the current Fabuwood Quality Standards sheet. The current Fabuwood Quality Standards sheet is available for download in the dealer login section of the Fabuwood website (www.fabuwood.com), which should be reviewed at each time a claim for warranty service is being considered. Fabuwood reserves the right to modify or change the Fabuwood Quality Standards sheet at any time without notice.

DISCLAIMERS

The following is a brief recap of some of the characteristics of the wood and finishes on the cabinets you are about to purchase. Please read them carefully. If some of these characteristics concern you, please choose something else. We bring these characteristics to your attention so you will realize that Fabuwood will not be held responsible for these variations in your cabinetry. It is important

to note that wood products claimed as defective are most often the result of atmospheric conditions such as excess moisture and humidity. Fabuwood strongly recommends testing the intended location of the products for such conditions prior to installation.

WOOD AND COLOR VARIATIONS: Wood is a product of nature, and since no two trees are alike, cabinets may vary in color, texture and grain. Wood characteristics naturally occurring such as variations in color, grain, mineral streaks, pinholes and knots are not considered defects. Color variations in cabinets are also a natural occurrence due to species, age, character of cabinets, and exposure to UV light and sunlight. For these reasons, new and/or replacement cabinets may not match display samples and/or existing cabinets. This may result in overall color variations, but is not considered a defect.

WOOD DOORS: Wood by nature will undergo expansion and contraction movements year after year as it compensates and adjusts to ever changing atmospheric humidity and temperature conditions. It is very common for center panels on doors to shrink, expand or move during these transitions. Typically, the panel will return to its normal position within a year once it has adjusted to seasonal changes. It is for these same reasons that it is very common for doors to warp during these periods. Doors that are warped up to 1/4" are not considered defective. Note: It is advisable to check if the door was properly installed, since doors that appear warped are very often the result of improper installation.

PAINTED FINISHES: Plywood is a non-porous, smooth grained wood. Additionally, wood by nature undergoes periods of expansion and contraction while it adjusts to atmospheric conditions mentioned above. As such, finish stress lines may become visible on painted cabinets especially at the joints. Any such occurrence is not considered a defect.

GLAZED FINISHES: A glazed finish by character is an uneven finish. Some edges and profiles will have heavier hang up than others and glazing may vary cabinet to cabinet, door to drawer and item to item. This may result in overall color variations but is not considered a defect.

WARRANTY PERFORMANCE

If a defect does occur within the terms and conditions of this warranty such defective part will be repaired or replaced by Fabuwood at its sole discretion. Fabuwood will not provide or pay for the cost of removal of defective product, transportation of defective, repaired or replaced product or installation of repaired or replaced product. Fabuwood will not be responsible for any shipping damages to the defective, replaced or repaired product. If defective item has been discontinued or is not available at the time, Fabuwood reserves the right to replace the item with the most similar item available in Fabuwood's inventory at that time. Fabuwood cannot guarantee that the finish of any replacement will exactly match the finish and appearance of the defective item due to the natural ageing process of the wood and finishes of the cabinets. Fabuwood may require at its discretion that the customer submit a clear photo, or that a company representative view the item being claimed before honoring this warranty.

CLAIMS

To submit a claim covered under this warranty, the original proof of purchase and full payment or copies thereof must be provided. Please email all documents to customerservice@fabuwood.com. Your dealer will contact you once your claim has been reviewed.

NOTE

Please do not send back any items to Fabuwood prior to receiving proper authorization from customer service. Fabuwood takes no responsibility on any items sent back to Fabuwood without proper return authorization.

Dealer Product & Warranty Awareness Form

I have carefully read and understand the entire warranty provided by Fabuwood and have been provided the opportunity to ask questions of, and receive answers from Fabuwood concerning the terms and conditions set forth in the warranty, including, but not limited, to the extent of the coverage therein.

I hereby accept full responsibility (a) to truthfully and accurately represent Fabuwood, and (b) to make sure that anyone selling Fabuwood cabinets under my dealership will properly explain the terms and conditions to the consumer.

I understand that Fabuwood is not liable for any claims made by any consumer that are not covered under the warranty and that I will be solely responsible for any and all losses and expenses arising from such claims. I agree to indemnify, defend and hold Fabuwood harmless from and against such losses and expenses, including, but not limited to, reasonable attorney's fees and expenses.

Printed Name

Signature

Company Name

Company Address

Witness Printed Name

Witness Signature

Date

Consumer Product & Warranty Awareness Form

I have read the entire warranty provided by Fabuwood and I understand the terms and conditions set forth by Fabuwood as well as the extent of the coverage of the warranty.

I understand and agree that (Dealer's name) _____ will not be liable for any defects and claims that are not covered under the warranty and that I will not hold (Dealer's name) _____ responsible for any such defects.

Printed Name

Signature

Company Name

Company Address

Witness Printed Name

Witness Signature

Date